

Flow Monitor & Flow Indicator

KM-335

KM-350



OVERVIEW

Operation

- Float measuring principle

Application

- Cooling systems and cooling circuits
- Mechanical engineering
- Pharmaceutical industry
- Chemical industry
- Research & Development

Features

- Shatterproof and corrosion resistant
- Easily removable from the pipe system
- Mounting for accessories (limit switches)
- Adhesive special scales, for liquid and gaseous media
- DN (rated width), measuring range, and material specified on the measuring tube

Installation information

- The operating instructions for KM-335, KM-350 must be observed!
- **Download: www.meister-flow.com**

OPERATING DATA

Operating pressure, max.	PN 10 (at 20 °C) ⁽¹⁾
Pressure drop	see table on page 6
Operating temperature	0 °C - 60 °C ⁽²⁾
Measuring accuracy	see table below

⁽¹⁾ See also Pressure - temperature - diagram on page 7

⁽²⁾ max. temperature at 1 bar

MATERIALS

Measuring tube:	PVC, PA, PSU
Float:	PVDF
Insert, lower:	PVDF
Insert, upper:	PVDF
Coupling ring:	PVC (optional PP)
Connector:	PVC (optional PP)
O-Rings:	EPDM (optional FPM)
Limit value indicator:	PS
Guide rail ⁽⁵⁾ :	PVDF / stainless steel

⁽⁵⁾ from DN 50 (1500 - 15000 l/h)

MEASURING RANGES

Type	Measuring range for H ₂ O at 20 °C ⁽³⁾	
	l/h	gpm
KM-3...-500	50 – 500	0,22 – 2,2
KM-3...-1000	100 – 1000	0,44 – 4,4
KM-3...-1500	150 – 1500	0,66 – 6,6
KM-3...-2500	250 – 2500	1,1 – 11
KM-3...-2000	200 – 2000	0,88 – 8,8
KM-3...-3000	300 – 3000	1,32 – 13,2
KM-3...-6000 ⁽⁴⁾	600 – 6000	2,64 – 26,4
KM-3...-10000	1000 – 10000	4,4 – 44,02
KM-3...-15000	1500 – 15000	6,6 – 66,04
KM-3...-20000	2000 – 20000	8,8 – 88
KM-3...-30000	3000 – 30000	13,2 – 132
KM-3...-60000	8000 – 60000	35,2 – 264

⁽³⁾ The specified measuring- / switch ranges are valid for water having a density of 1.00 kg/dm³, vertical installation of the device and flow direction from bottom to top.

Other installation positions or deviation from the operating densities will increase the measurement error specified in the data sheet.

Operating density for water at 20 °C and 1.013 bar (absolute value): 1.00 kg/dm³.

Upon request, special scales for deviating media and different operating conditions, are available.

Special scales for air see page 7

Special scales for HCl 30 - 33 %, NaOH 30 % and NaOH 50 % see page 7

⁽⁴⁾ Available in DN 40 and DN 50

ACCURACY

Accuracy class 4, VDE/VDI 3513, sheet 2

Flow in %	10	20	30	40	50	60	70	80	90	100
Total error of measurement in %	13	8	6,33	5,5	5	4,67	4,43	4,25	4,11	4
Total error of full scale in %	1,3	1,6	1,9	2,2	2,5	2,8	3,1	3,4	3,7	4

ASSEMBLY DRAWING

Process connection with solvent cement socket PVC or weld socket PP

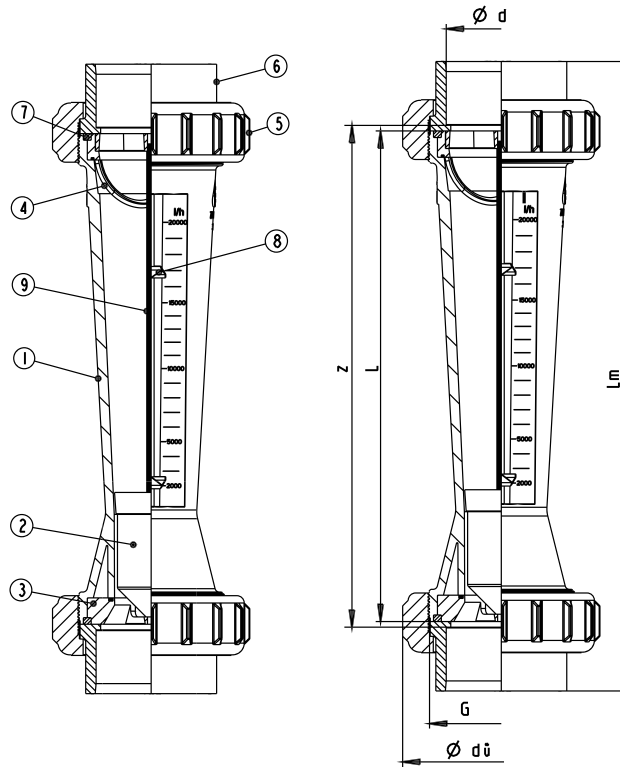

PARTS DESCRIPTION

Item	Description	No. of pieces	Material
01	Measuring tube:	1	PVC, PA, PSU
02	Float:	1	PVDF
03	Insert, lower:	1	PVDF
04	Insert, upper:	1	PVDF
05	Coupling ring:	2	PVC (optional PP)
06	Connector:	2	PVC (optional PP)
07	O-Ring:	2	EPDM (optional FPM)
08	Limit value indicator:	2	PS
09	Guide rail ⁽⁶⁾	1	PVDF / stainless steel

⁽⁶⁾ from DN 50 (1500 - 15000 l/h)

TECHNICAL DRAWING

Process connection with weld socket (butt end) PP

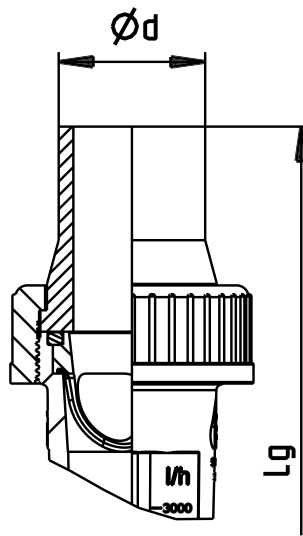

Process connection with threaded socket PVC, PP annealed cast iron or stainless steel

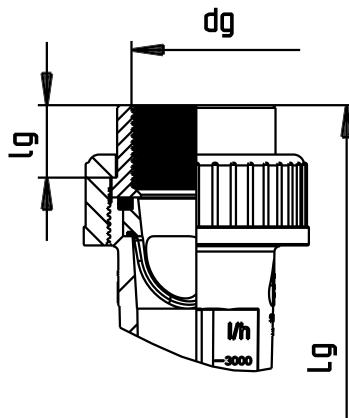

SUMMARY OF TYPES

Type	Overall dimensions [mm]					Solvent cement socket PVC			Weld socket PP			PP-Socket (butt end)			Threaded socket			Weight approx.	
	DN	d	G	d _u	L	d _m	z	L _m	d _m	z	L _m	d	L _g	S ⁽⁷⁾	d _g	L _g	l _g	[g]	
																			PA
																			PSU
																			PVC
KM-335-500	25	32	1 1/2"	60	335	32	341	385	32	345	381	32	455	2,9	1"	385	17	520	
KM-335-1000	25	32	1 1/2"	60	335	32	341	385	32	345	381	32	455	2,9	1"	385	17	520	
KM-335-1500	32	40	2"	72	335	40	341	393	40	345	385	40	461	3,7	1 1/4"	393	19	600	
KM-335-2500	32	40	2"	72	335	40	341	393	40	345	385	40	461	3,7	1 1/4"	393	19	600	
KM-335-2000	40	50	2 1/4"	83	335	50	341	403	50	345	391	50	467	4,6	1 1/2"	403	23	1220	
KM-335-3000	40	50	2 1/4"	83	335	50	341	403	50	345	391	50	467	4,6	1 1/2"	403	23	1220	
KM-335-6000	40	50	2 1/4"	83	335	50	341	403	50	345	391	50	467	4,6	1 1/2"	403	23	1220	
KM-335-6000	50	63	2 3/4"	103	335	63	341	417	63	345	399	63	473	5,8	2"	417	23	1680	
KM-335-10000	50	63	2 3/4"	103	335	63	341	417	63	345	399	63	473	5,8	2"	417	23	1680	
KM-335-15000	50	63	2 3/4"	103	335	63	341	417	63	345	399	63	473	5,8	2"	417	23	1680	
KM-335-20000	65	75	3 1/2"	122	335	75	341	429	75	345	407	75	587	6,9	2 1/2"	–	–	2900	
KM-335-30000	65	75	3 1/2"	122	335	75	341	429	75	345	407	75	587	6,9	2 1/2"	–	–	2900	
KM-335-60000	65	75	3 1/2"	122	335	75	341	429	75	345	407	75	587	6,9	2 1/2"	–	–	2900	

Type	Overall dimensions [mm]					Solvent cement socket PVC			Weld socket PP			PP-Socket (butt end)			Threaded socket			Weight approx.	
	DN	d	G	d _u	L	d _m	z	L _m	d _m	z	L _m	d	L _g	S ⁽⁷⁾	d _g	L _g	l _g	[g]	
																			PA
																			PSU
																			PVC
KM-350-500	25	32	1 1/2"	60	350	32	356	400	32	360	396	32	460	2,9	1"	400	17	520	
KM-350-1000	25	32	1 1/2"	60	350	32	356	400	32	360	396	32	460	2,9	1"	400	17	520	
KM-350-1500	32	40	2"	72	350	40	356	408	40	360	400	40	476	3,7	1 1/4"	408	19	600	
KM-350-2500	32	40	2"	72	350	40	356	408	40	360	400	40	476	3,7	1 1/4"	408	19	600	
KM-350-2000	40	50	2 1/4"	83	350	50	356	418	50	360	406	50	482	4,6	1 1/2"	418	23	1220	
KM-350-3000	40	50	2 1/4"	83	350	50	356	418	50	360	406	50	482	4,6	1 1/2"	418	23	1220	
KM-350-6000	40	50	2 1/4"	83	350	50	356	418	50	360	406	50	482	4,6	1 1/2"	418	23	1220	
KM-350-6000	50	63	2 3/4"	103	350	63	356	432	63	360	414	63	488	5,8	2"	432	23	1680	
KM-350-10000	50	63	2 3/4"	103	350	63	356	432	63	360	414	63	488	5,8	2"	432	23	1680	
KM-350-15000	50	63	2 3/4"	103	350	63	356	432	63	360	414	63	488	5,8	2"	432	23	1680	
KM-350-20000	65	75	3 1/2"	122	350	75	356	444	75	360	422	75	602	6,9	2 1/2"	444	–	2900	
KM-350-30000	65	75	3 1/2"	122	350	75	356	444	75	360	422	75	602	6,9	2 1/2"	444	–	2900	
KM-350-60000	65	75	3 1/2"	122	350	75	356	444	75	360	422	75	602	6,9	2 1/2"	444	–	2900	

⁽⁷⁾ Wall thickness

COMBINATIONS

Measuring tube	Float	Insert upper and lower	O-Ring
PVC	PVDF	PVDF	EPDM (optional FPM)
PA	PVDF	PVDF	EPDM (optional FPM)
PSU	PVDF	PVDF	EPDM (optional FPM)

CONNECTION OPTIONS

Socket	Socket (butt end)	Plastic, internal thread	Metal, internal thread
PVC solvent cement socket (standard)	PP weld socket (butt end)	PVC	Stainless steel V4A
PP weld socket		PP	Annealed cast iron

PRESSURE DROP

Type	Measuring range	Pressure drop
	l/h	mbar
KM-335-500 / KM-350-500	50 – 500	22,84
KM-335-1000 / KM-350-1000	100 – 1000	22,84
KM-335-1500 / KM-350-1500	150 – 1500	22,84
KM-335-2500 / KM-350-2500	250 – 2500	22,84
KM-335-2000 / KM-350-2000	200 – 2000	24,99
KM-335-3000 / KM-350-3000	300 – 3000	24,99
KM-335-6000 / KM-350-6000 ^(*)	600 – 6000	24,99
KM-335-10000 / KM-350-10000	1000 – 10000	24,99
KM-335-15000 / KM-350-15000	1500 – 15000	28,23
KM-335-20000 / KM-350-20000	2000 – 20000	45,67
KM-335-30000 / KM-350-30000	3000 – 30000	45,67
KM-335-60000 / KM-350-60000	6000 – 60000	47,24

^(*) Available in DN 40 and DN 50

SPECIAL SCALES

Type	Measuring range				
	H ₂ O	Air	HCl 30 - 33 %	NaOH 30 %	NaOH 50 %
	I/h	Nm ³ /h	I/h	I/h	I/h
KM-3...-500	50 – 500	2 – 15	40 – 430	30 – 320	10 – 62
KM-3...-1000	100 – 1000	3,5 – 30	80 – 860	70 – 660	10 – 195
KM-3...-1500	150 – 1500	5 – 45	150 – 1250	100 – 900	20 – 350
KM-3...-2500	250 – 2500	8 – 76	200 – 2150	100 – 1600	5 – 760
KM-3...-2000	200 – 2000	7 – 60	200 – 1850	200 – 1400	5 – 540
KM-3...-3000	300 – 3000	10 – 87	300 – 2500	300 – 1950	105 – 1200
KM-3...-6000 ⁽⁹⁾	600 – 6000	20 – 170	600 – 4900	500 – 3800	400 – 2350
KM-3...-6000 ⁽¹⁰⁾	600 – 6000	25 – 180	600 – 5400	500 – 4300	100 – 2200
KM-3...-10000	1000 – 10000	30 – 280	800 – 8400	600 – 6600	100 – 4000
KM-3...-15000	1500 – 15000	50 – 440	1000 – 12750	750 – 9500	300 – 5000
KM-3...-20000	2000 – 20000	70 – 580	2000 – 17500	1300 – 13000	200 – 7000
KM-3...-30000	3000 – 30000	100 – 900	3000 – 26500	2600 – 20000	400 – 9800
KM-3...-60000	6000 – 60000	230 – 1650	6000 – 50000	6000 – 40000	2000 – 15000

⁽⁹⁾ DN 40

⁽¹⁰⁾ DN 50

PRESSURE - TEMPERATURE - DIAGRAM

The curves in the diagram represent values for the durability of three different materials in relation to the operating temperature.

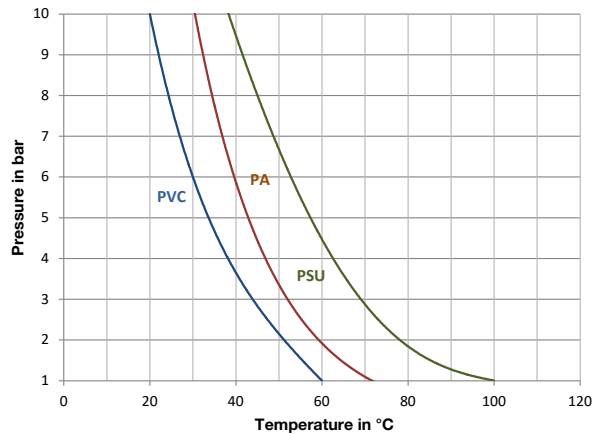

■ LIMIT SWITCH CONTACT ZNC AND ZNO

■ APPLICATION

The limit switch contacts are used to monitor flow limits. They are slid onto the guide located on the flowmeter and can be set to any value of the corresponding scale.

■ ILLUSTRATION



■ OPERATION

A built-in magnet in the float closes or opens a Reed contact encapsulated in the switch housing. The switching function is bistable, that is, the switching state is maintained, even when the magnetic float is away from the contact.

■ SWITCHING STATE

Contact		Float (above)	Float (below)
ZNC	(Normally closed) / MIN	open	closed
ZNO	(Normally open) / MAX	closed	open

■ TECHNICAL DATA

Switching voltage ⁽¹³⁾	max. 230 V~
Switching capacity ⁽¹³⁾	max. 10 W / 12 VA
Switching current ⁽¹³⁾	max. 0,5 A
Contact resistance	< 200 mΩ
Insulation resistance	> 10 ¹¹ Ω
Permissible ambient temperature	0 °C - 55 °C
Ingress Protection	IP65 (DIN 40050)
Switch-on / -off hysteresis	1 - 2 mm

⁽⁷⁾ Exceeding these values, even temporarily, is not allowed.

ANALOG TRANSMITTER ZAT-300

DESCRIPTION

The analog transmitter provides an output signal of 4 - 20 mA corresponding to the vertical position of the magnetic float in the flowmeter.

Please note:

Since the resolution of the various scales are different, the transmitters are factory set to the respective measuring range. Therefore, when ordering, always specify the required measuring range.

ILLUSTRATION

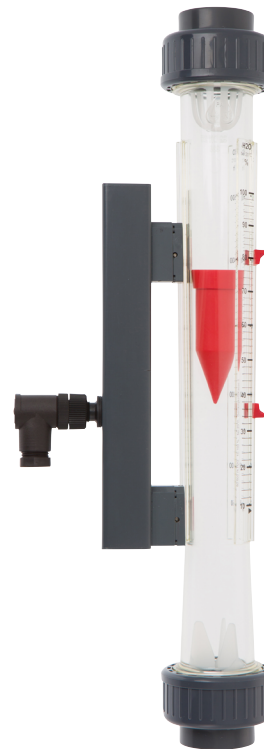

ELECTRICAL CONNECTION

PIN 1:	Operating voltage	12 - 24 V
PIN 2:	Output signal	4 - 20 mA
PIN 3:		0 V

TECHNICAL DATA

Supply voltage	2 - 24 VDC ($\pm 10\%$)
Power consumption	< 50 mA
Load resistance	max. 500 Ω
Current output	4 - 20 mA (3-wire)
Ingress Protection	IP65
Ambient temperature	0 - 50 °C
Connection	Connector DIN 43650
Accuracy	< 1 %

TECHNICAL DRAWING

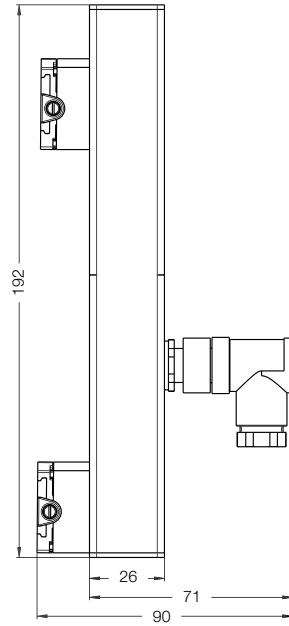

ASSEMBLY DRAWING

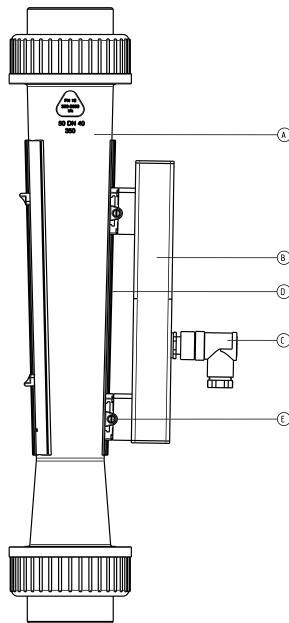

FUNCTIONAL ELEMENTS

Letter	Description
A:	Flow meter KM-335 / 350 with magnetic float
B:	Analog transmitter ZAT-300
C:	Connector
D:	Guide rail
E:	Screws for locking and adjusting the sensor